

● Swan Class Sloops Plans Set ●

By David Antscherl

Distributed by: SeaWatchBooks LLC, Florence, Oregon
www.seawatchbooks.com, seawatchbooks@gmail.com

Without a doubt, one of the finest references on Eighteenth Century men of war is the four-volume set, *The Fully Framed Model, HMN Swan Class Sloops, 1767—1780*, by David Antscherl and Greg Herbert. This benchmark series was supplemented by a set of plans marketed by Antscherl and Herbert that assisted the model maker who wished to build a fully framed model. Originally created by Mr. Antscherl, they were used by Herbert while he was building “Pegasus,” which is the basis for Volume III in the series. Not long ago it was announced that these plans would no longer be available.

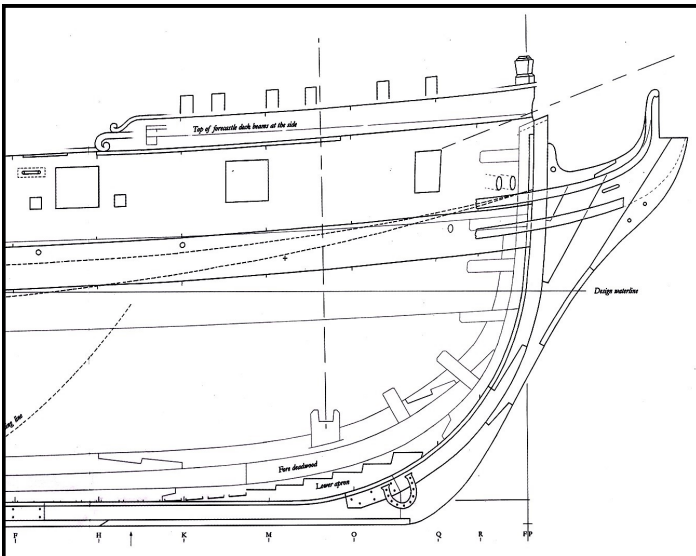

Bob Friedman of SeaWatchBooks stepped in, and worked out the details that resulted in a portfolio of seven plans being offered for a limited time at a reasonable price. Drawn to a scale of 1:48, this set provides the sheer, profile, half-breadth, and body plan that represent a generic Swan class vessel. Drawings are also provided for all the fore and aft cant frames, hawse timbers, transoms, and deck beams. Patterns are featured for each pair of frames, and include the locations for the chocks, spacer blocks and scarph joints.

One nice touch concerning the frame drawings is the use of vertical and horizontal reference scales. These lines measure 5” in length, and confirm the accuracy of the plans. Every frame pattern was checked, and they were all perfect.

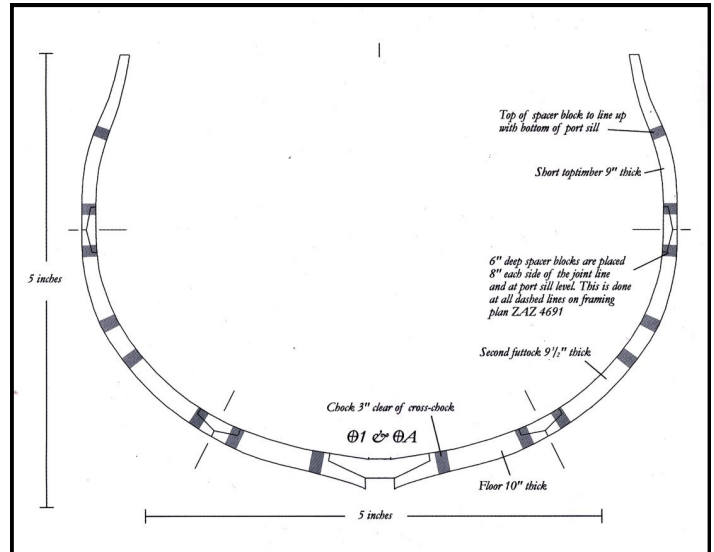

This package of drawings is not entirely devoted to the hull. An added bonus is an entire sparring plan that is applicable to sixth rate vessels.

Every yard, mast, boom, and top are featured, along with full size dimensions. Attention to detail is quite evident on this 20” x 34” sheet. It is exemplified by the details provided for a fish davit and fire boom, which are rarely covered by most references.

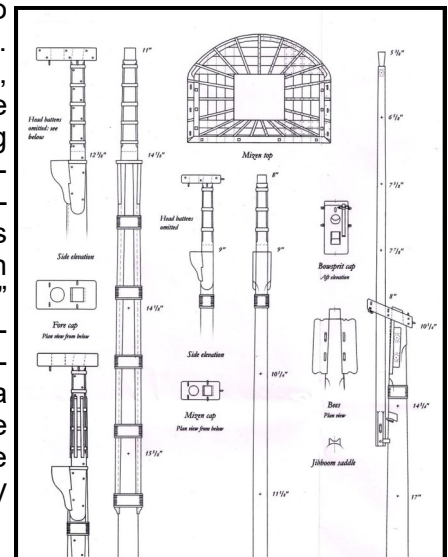

In addition to these plans and the four-volume set *The Fully Framed Model, HMN Swan Class Sloops, 1767—1780*, copies of contemporary plans of a “Swan” class vessel from the Royal Museum Greenwich will be needed to complete an accurate model. Twenty five of these sloops of war were constructed, and “as built” plans exist for many of them. However, some plans offer more details than others. A list, and ordering information, can be found in Volume 1 and at www.admiraltymodels.com.